



PIPE TOOLS & VISES  
SINCE 1896

# Filter-Regulator-Lubricator (FRL)

## Instructions

FIGURE 1

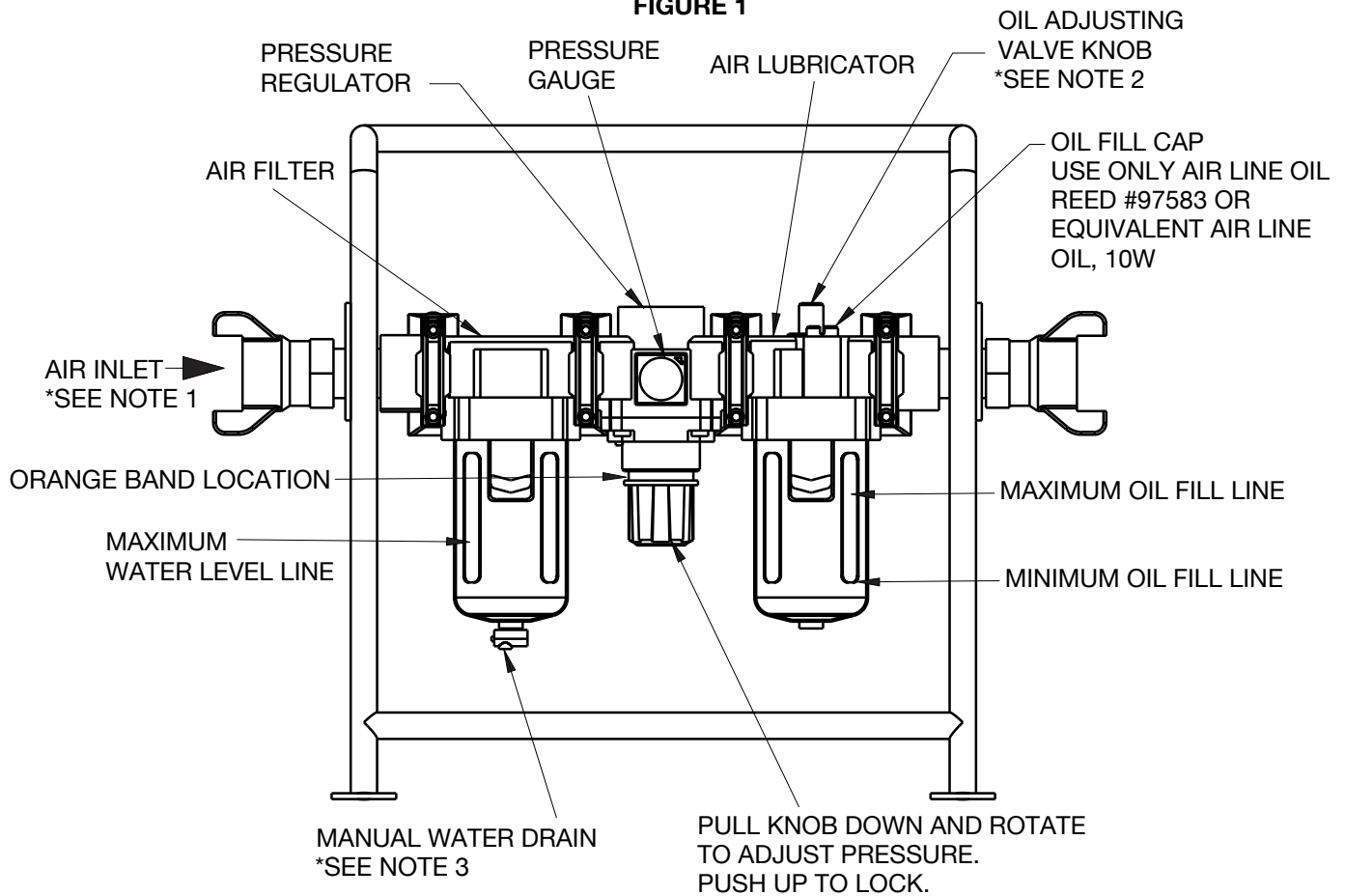

FIGURE 2



### NOTES:

1. Use clean dry air. Air containing excessive water will cause damage. MAX PRESSURE that can be used with this FRL is 120 PSI.
2. Oil amount adjusting valve is operated manually. Counterclockwise rotation increases amount. Three turns opens valve fully. Numbers on scale do not indicate drop amounts.
3. Periodically check water level in air filter bowl. Remove water by depressing small red button (MANUAL WATER DRAIN) on bottom of air filter bowl.

| Item Code | Description                               |
|-----------|---|
| 47506     | Filter Element Replacement for Air Filter |
| 97583     | Air Line Oil, 16 oz.                      |
| 97588     | Motor Grease, 2 oz.                       |

### FRL Operation

It is imperative that a filter, regulator, lubricator (FRL) be employed when running pneumatic tools. The air should be clean, dry, and lubricated to maximize life and performance of the pneumatic tool. Maximum pressure for the FRL is 120 psi.

### Use Nonfluid Oil<sup>®</sup> Air Lubricant

This product mixes with water and via the Air Lubricator is introduced as a mist in the air stream to provide lubrication. Nonfluid lubricating oil is sold by Reed as UPOIL #97583, 16 ounces.

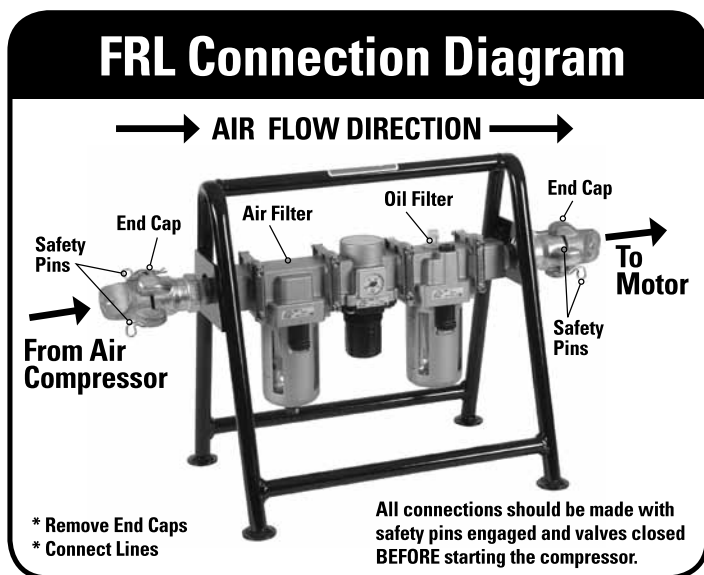
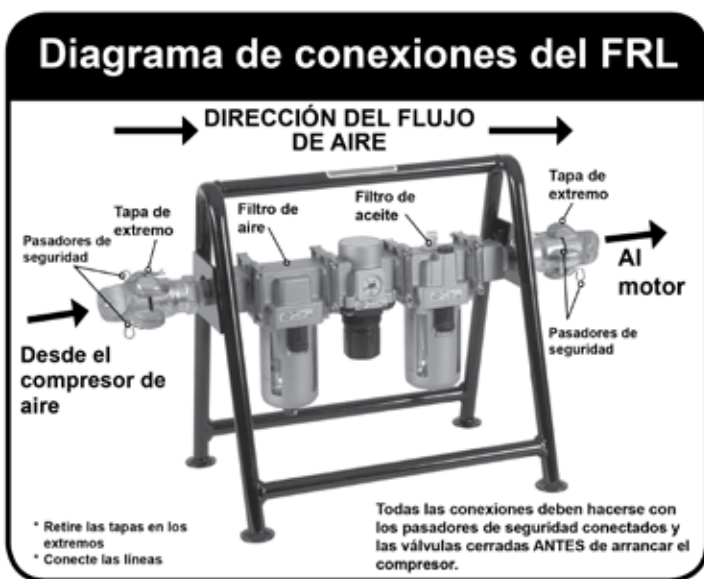

FIGURE 3



### Operation

Connect the airlines to the FRL. The direction of the air flow is indicated by arrows on the top of the FRL. With the pneumatic tool connected and in the off position, turn on the supply air to the FRL. Check the level of fluids in the clear bowls on the bottom of the Air Filter and Air Lubricator.

If the air filter bowl contains water, drain the bowl by pressing and holding the small button on the bottom of the bowl until the water is completely drained. Observe the maximum water level line on the metal protective shield of the bowl. Water can be drained with either the air supply on or off.

The oil level in the air lubricator must be maintained for proper lubrication of the pneumatic tool. The minimum and maximum oil levels are indicated on the metal protective shield of the oiler bowl. To add oil, remove the black oil plug at the top of the oiler with a 1/4" hex wrench, add oil and replace the plug. USE NON-FLUID OIL. Oil can be added with either the air supply on or off.

The air pressure is indicated on the dial gauge on the front of the Pressure Regulator. To adjust the air pressures, pull the large black knob below the gauge down to the unlocked position. When unlocked, an orange band can be observed on the top of the knob (Figure 1). Turn the knob clockwise to increase the pressure. When the desired pressure is reached push the knob up to the locked position. (The orange band is no longer visible.)

The amount of lubricant supplied to the pneumatic tool is regulated by the number of drops of oil per minute and is observed through the site window of the oil adjusting valve knob at the top of the Air Lubricator (Figure 1). Check the specific pneumatic tool manual for lubrication requirements. Numbers on the scale of the adjusting knob do not indicate drop amounts. Turn the adjusting knob clockwise to the off position then turn that same knob counter clockwise until the indication mark is on 4 or 5. This is a good starting point. The tool must be running to adjust the number of drops per minute of lubricant. With the pneumatic tool running, turn the knob to adjust to the required number of drops. Counterclockwise will increase the number of drops.

The FRL bowls need periodic inspection during the use of the pneumatic tool.