

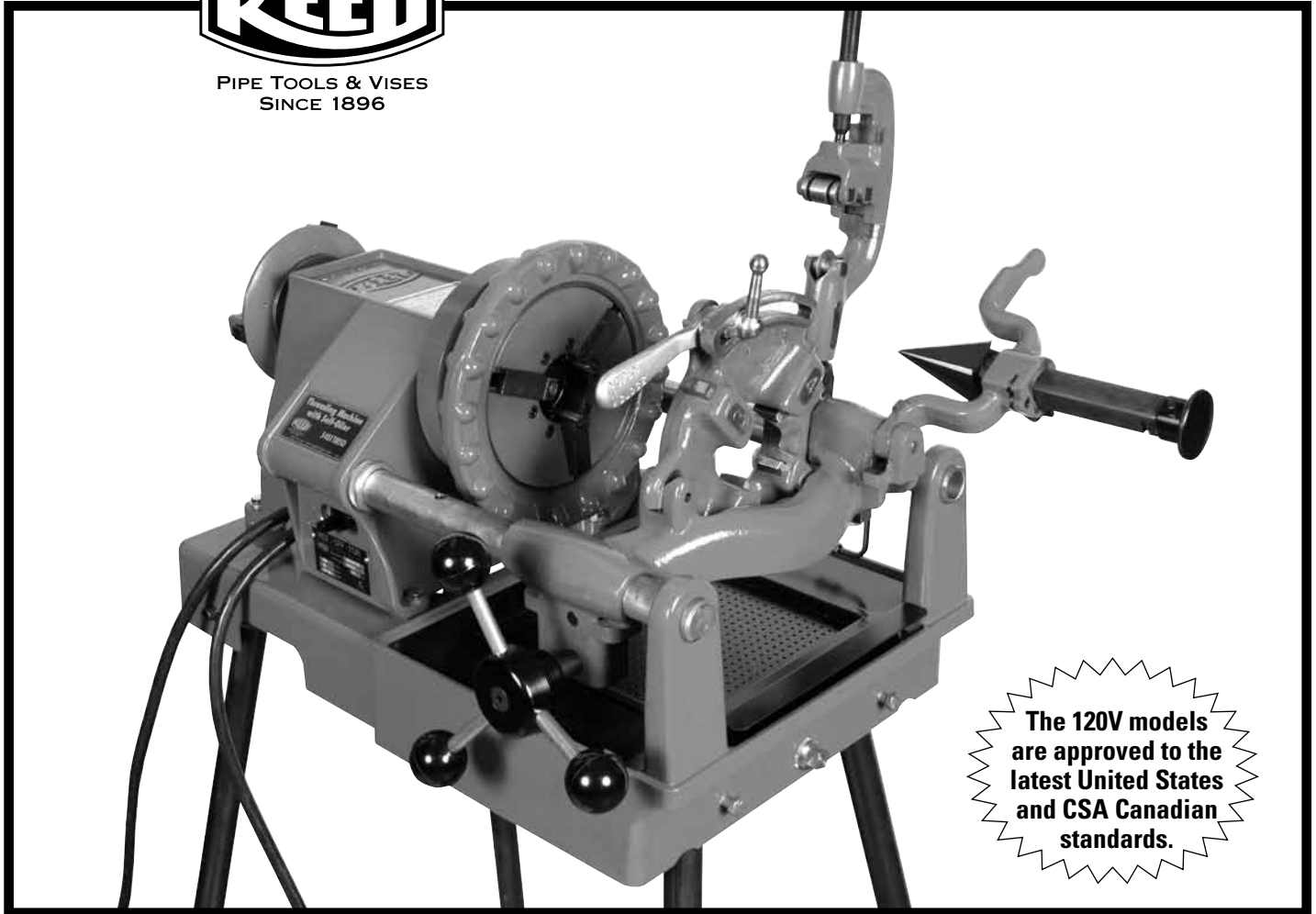

PIPE TOOLS & VISES
SINCE 1896



The 120V models
are approved to the
latest United States
and CSA Canadian
standards.

5401TMSO Threading Machine with Self-Oiler

OPERATOR'S MANUAL

The electric-motor-driven REED 5401TMSO Threading Machine with Self Oiler centers and chucks pipe and conduit and rotates it while cutting, threading, and reaming operations are performed.

- Covers 120V and 240V models.
- Includes Footswitch.
- Footswitch cord is 5' 6" (1676 mm) long.



WARNING!

READ AND UNDERSTAND ALL INSTRUCTIONS.
FAILURE TO FOLLOW ALL INSTRUCTIONS LISTED
INSIDE MAY RESULT IN ELECTRIC SHOCK, FIRE,
AND/OR SERIOUS PERSONAL INJURY.

SAVE THESE INSTRUCTIONS!

REED MANUFACTURING COMPANY

1425 WEST 8TH ST. P.O. BOX 1321, ERIE, PA 16512 USA PHONE: 800-666-3691 OR 814-452-3691 FAX: 800-456-1697 OR 814-455-1697

www.reedmfgco.com

1120-55401

TABLE OF CONTENTS

General Safety Information.....	3
Work Area Safety	3
Electrical Safety	3
Personal Safety	3
Tool Use and Care	4
Service	4
Specific Safety Information	4
Foot Switch Safety	4
Threading Machine Safety	5
Machine Maintenance	5
Description, Specifications, and Accessories	5
Description	5
Specifications	5
Accessories	5
Operation Using Threading Machine Mounted Tools	6
Installing Pipe in Threading Machine.....	6
Cutting Pipe with 05366 Cutter	6
Reaming Pipe with 05308 Reamer	7
Threading Pipe with R811 Die Head	7
Installing Dies in R811 Universal Die Head	8
Maintenance Instructions.....	8
Jaw Insert Replacement	8
Lubrication	8
Motor Brush Replacement	8
Motor Replacement	8
Self-Oiling System	9
Procedure for Installing the Legs	9
Parts Diagrams	10
5401TMSO (120V and 240V) Threading Machine	10
5401TMSO Threading Machine Base	11
5401TMSO (120V) Motor Assembly	12
5401TMSO (240V) Motor Assembly	13
5401TMSO Carriage With Handwheel	14
5401TMSO Pipe Cutter	15
5401TMSO Reamer	16
5401TMSO (120V) Electrical Assembly.....	17
5401TMSO (120V) Wiring Schematic and Wiring Diagram	17
5401TMSO (240V) Electrical Assembly.....	18
5401TMSO (240V) Wiring Schematic and Wiring Diagram	18
REED Warranty	18

GENERAL SAFETY INFORMATION

WARNING: READ AND UNDERSTAND ALL INSTRUCTIONS. FAILURE TO FOLLOW ALL INSTRUCTIONS LISTED MAY RESULT IN ELECTRIC SHOCK, FIRE, AND/OR SERIOUS PERSONAL INJURY.

SAVE THESE INSTRUCTIONS!

WORK AREA SAFETY

1. **Keep work area clean and well lit.** Cluttered benches and dark areas invite accidents.
2. **Do not operate tools in explosive atmospheres,** such as in the presence of flammable liquids, gases, or dust. Tools create sparks which may ignite the dust or fumes.
3. **Keep by-standers, children, and visitors away while operating a tool. Distractions can cause you to lose control.**
4. **Do not let visitors contact the tool or extension cord.** Such preventative measures reduce the risk of injury.

ELECTRICAL SAFETY

1. **Grounded tools must be plugged into an outlet, properly installed and grounded in accordance with all codes and ordinances.** Never remove the grounding plug or modify the plug in any way. Do not use adapter plugs. Check with a qualified electrician if you are in doubt as to whether the outlet is properly grounded. If the tool should electrically malfunction or break down, grounding provides a low resistance path to carry electricity away from the user.
2. **Avoid body contact with grounded surfaces** such as pipes, radiators, ranges and refrigerators. There is an increased risk of electrical shock if your body is grounded.
3. **Do not expose electrical parts to rain or wet conditions.** Water entering a tool will increase the risk of electrical shock.
4. **Do not abuse cord.** Never use the cord to carry the tools or pull the plug from the outlet. Keep cord away from heat, oil, sharp edges or moving parts. Replace damaged cords immediately. Damaged cords increase the risk of electrical shock.
5. **When operating a tool outside,** use an outdoor extension cord marked "W-A" Or "W". These cords are rated for outdoor use and reduce the risk of electrical shock.

6. **Connect the tool to an AC power supply** that matches the name plate specification. Incorrect voltage supply can cause electrical shock or burns.
7. **Use only three-wire extension cords** which have three-prong grounding plugs and three-pole receptacle which accept the tool's plug. Use of other extension cords will not ground the tool and increase the risk of electrical shock.
8. **Use proper extension cords** (see Chart). Insufficient conductor size will cause excessive overheating.
9. **Keep all extension cord connections dry and off the ground.** Do not touch plugs or tool with wet hands. Reduces the risk of electrical shock.

Minimum Wire Gauge for Cord Set			
Nameplate Amps	TOTAL LENGTH (IN FEET)		
	0 - 25	26 - 50	51 - 100
0 - 6	18 AWG	16 AWG	16 AWG
6 - 10	18 AWG	16 AWG	14 AWG
10 - 12	16 AWG	16 AWG	14 AWG
12 - 16	14 AWG	12 AWG	NOT RECOMMENDED

PERSONAL SAFETY

1. **Stay alert, watch what you are doing and use common sense when operating a tool.** Do not use tool while tired or under the influence of drugs, alcohol, or medications. A moment of inattention while operating power tools may result in serious personal injury.
2. **Dress properly. Do not wear loose clothing or jewelry. Contain long hair.** Keep hair, clothing, and gloves away from moving parts. Loose clothes, jewelry, or long hair can be caught in moving parts.
3. **Avoid accidental starting. Be sure switch is OFF before plugging in.** Carrying tools with your finger on the switch or plugging in tools that have the switch on invites accidents.
4. **Do not overreach.** Keep proper footing and balance at all times. Proper footing and balance enables better control of the tool in unexpected situations.
5. **Use safety equipment.** Always wear eye protection. Dust mask, non-skid safety shoes, hard hat, or hearing protection must be used for appropriate conditions.
6. **Operate machine from side with REV/OFF/FOR switch.**



TOOL USE AND CARE

1. **Use clamp or other practical way to secure and support the workpiece to a stable platform.** Holding the work by hand or against your body is unstable and may lead to loss of control.
2. **Do not force tool.** Use the correct tool for your application. The correct tool will do the job better and safer at the rate for which it is designed.
3. **Do not use tool if switch does not turn it ON or OFF.** Any tool that cannot be controlled with the switch is dangerous and must be repaired.
4. **Disconnect the plug from the power source before making any adjustments, changing accessories, or storing the tool.** Such preventive safety measures reduce the risk of starting the tool accidentally.
5. **Store idle tools out of the reach of children and other untrained persons.** Tools are dangerous in the hands of untrained users.
6. **Maintain tools with care.** Keep cutting tools sharp and clean. Properly maintained tools with sharp cutting edges are less likely to bind and are easier to control.
7. **Check for misalignment** or binding of moving parts, breakage of parts, and any other condition that may affect the tool's operation. If damaged, have the tool serviced before using. Many accidents are caused by poorly maintained tools.
8. **Use only accessories that are recommended by the manufacturer for your model.** Accessories that may be suitable for one tool may become hazardous when used on another tool.
9. **Inspect tool and extension cords periodically and replace if damaged.** Damaged cords increase the risk of electrical shock.
10. **Keep handles dry and clean;** free from oil and grease. Allows for better control of the tool.
11. **Store tools in dry place.** Such measures reduce risk of electrical shock.

SERVICE

1. **Tool service must be performed only by qualified repair personnel.** Service or maintenance performed by unqualified repair personnel could result in injury.
2. **When servicing a tool, use only identical replacement parts.** Follow instructions in the Maintenance section of this manual. Use of unauthorized parts or failure to follow maintenance instructions may create a risk of electrical shock or injury.
3. **Follow instructions for lubricating** and changing accessories. Accidents are caused by poorly maintained tools.

SPECIFIC SAFETY INFORMATION

The Operator's Manual contains specific safety information and instructions for your protection against serious injuries including:

- Loss of fingers, hands, arms or other body parts if clothing or gloves get caught in moving parts;
- Electric shock or burns from contact with wires, motor or other power drive parts;
- Impact injuries, including broken bones if machine tips over or workpiece falls;
- Eye injuries, including being blinded by the workpiece or workpiece chips.
- Read and follow safety labels on machine.
- Know the location and functions of all controls before using.

FOOT SWITCH SAFETY

The foot switch increases safety. The switch shuts off the motor upon removing your foot. Clothing caught in a rotating tool can pull the operator into the machine. Additionally, the machine's high torque could crush or break bones should caught or trapped clothing bind around your arm or other body parts.

WARNING



CLOTHING/GLOVES CAN BE CAUGHT IN MOVING PARTS. FINGERS, HANDS, ARMS OR OTHER BODY PARTS CAN BE CRUSHED OR BROKEN.

- Make sure switch is in the OFF position before plugging in power cord.
- Use foot switch.
- Do not wear gloves.
- Keep sleeves and jacket buttoned.
- Do not reach across machine. Clothing can be drawn into moving parts.
- Operate machine from switch side only.
- Do not block or disconnect foot switch.
- Keep foot switch in working order.
- Make sure you can quickly remove your foot from foot switch.
- Keep hands away from rotating pipe and fittings. Stop machine when screwing fittings on pipe or wiping threads.



THREADING MACHINE SAFETY

1. **Machine is made to thread and cut pipe or bolt.**
Follow instructions in Operator's Manual on machine uses. Do not use threading machine for other jobs including hole drilling, winch turning, and making/breaking fittings. Other uses may increase the risk of injury.
2. **Secure machine to bench or stand.** This prevents tipping.
3. **Support long heavy pipe with pipe supports.** This prevents tipping.
4. **Do not wear gloves or loose clothing.** Keep sleeves and jackets buttoned. If clothing should become caught in the machine, it will continue to wind up, pulling you into the machine and possibly resulting in serious injury.
5. **Do not reach across the machine or pipe.** Operating the machine from the side with REV/OFF/FOR switch eliminates reaching across.
6. **Do not use machine if foot switch is broken or absent.** The foot switch works as a safety device in preventing serious injury.
7. **Tighten chuck handwheel and engage rear centering device on the pipe before starting the machine.**
8. **Keep hands away from rotating pipe and fittings.** Let the machine stop completely before touching the work. Wipe threads and attach fittings only after the machine stops.
9. **Keep covers in place.** Exposed moving parts may offer a chance for clothing or body parts to become caught in the machinery.

MACHINE MAINTENANCE

1. **Use sharp cutting tools.**
2. **Grease front and rear bearings every 8 hours of use.**
3. **Inspect machine cord.** Replace damaged, frayed, broken or worn machine cord.
4. **Inspect extension cords.** Repair or replace damaged, frayed, broken or worn cords.
5. **Keep handles dry and clean.** Keep free from oil and grease.
6. **When not being used, store machine in a secured, locked area, out of reach of children and people unfamiliar with the threading machine.**
7. **Keep foot switch in working order.**

DESCRIPTION, SPECIFICATIONS AND ACCESSORIES

DESCRIPTION

The REED 5401TMSO Threading Machine with Self-Oiler is an electric-motor-driven threading machine which centers and chucks pipe and conduit and rotates it while cutting, threading, and reaming operations are performed.

SPECIFICATIONS

Threading Capacity:

Pipe 1/8" through 2"

Bolt 1/4" through 2"

Chuck:..... Chuck with replaceable jaw inserts.

Rear Centering Device:.. Cam action rotates with chuck

Support Bar (2):..... Heavy-duty

Switch (REV/OFF/FOR).. Heavy-duty, bump-proof and reversible

Motor: Universal Type

Horsepower..... 1/2HP

Volts..... 120 VAC single phase 50/60 Hz
240 VAC single phase 50/60 Hz

Spindle Speed:.....38 RPM

Oil Pump:..... Self Priming Gerotor Pump

Foot Switch (ON/OFF):... Oil and water tight

5401TMSO Weight: 175 lbs. (79.4 Kg)

Accessories/Related Products

05380 R811 Universal Die Head

UNIVERSAL DIES

05810	1 - 2" NPT	ALLOY
05805	1/2 - 3/4" NPT	ALLOY
05870	1 - 2" BSPT	HSS
05865	1/2 - 3/4" BSPT	HSS
05820	1 - 2" NPT	HSS
05815	1/2 - 3/4" NPT	HSS
05830	1 - 2" NPT	HSS for Stainless
05825	1/2 - 3/4" NPT	HSS for Stainless

OPERATION USING THREADING MACHINE MOUNTED TOOLS

WARNING:
OPERATOR SHOULD BE THOROUGHLY FAMILIAR
WITH SAFETY PRECAUTIONS BEFORE ATTEMPTING
TO OPERATE THIS EQUIPMENT.

**CORRECT OPERATING POSITION FOR CUTTING,
THREADING AND REAMING IS TO STAND ON THE
SWITCH SIDE OF THE THREADING MACHINE WITH
LEFT FOOT OPERATING FOOT SWITCH.**

Installing Pipe in Threading Machine

1. Measure and mark length of pipe being worked.
2. If pipe is long enough to be retained by centering device, insert pipe through front or rear of machine. If pipe is short, insert into front of machine.
3. Make certain that pipe is centered in centering device, if used, and lightly tighten centering device.
4. Tighten CHUCK JAWS with a repetitive, counter-clock wise snap spin of HANDWHEEL. This hammering action tightens jaws on pipe. A clockwise rotation snap spin releases jaws.

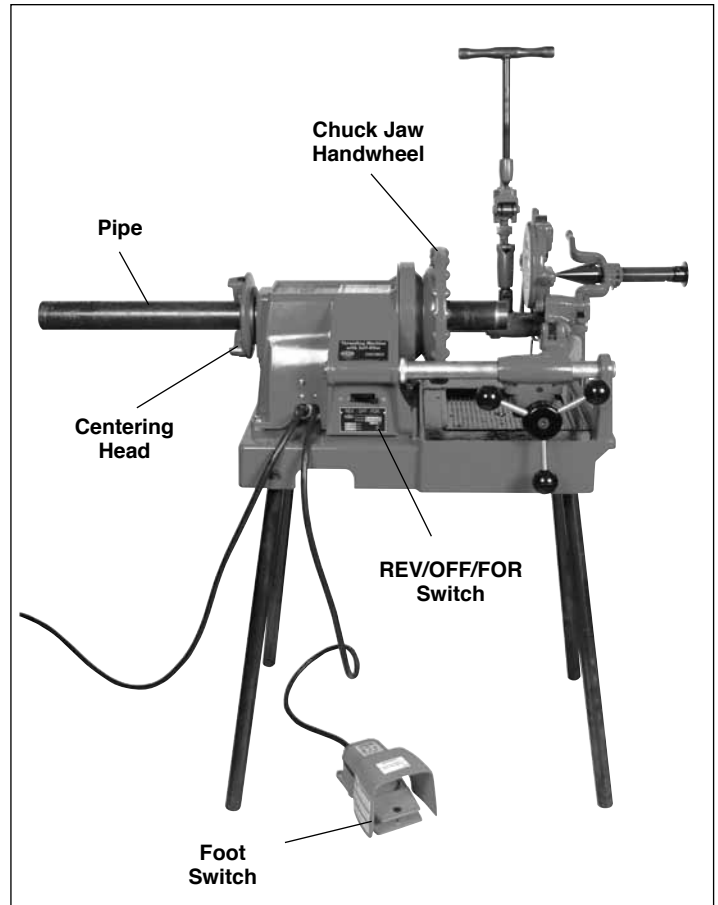

Figure 1 5401TMSO Threading machine with Self Oiler

Cutting Pipe with 05366 Cutter

1. Swing reamer and threader back to out-of-way position.
2. Move pipe cutter down onto pipe and move carriage with carriage handwheel to line up cutter wheel with mark on pipe (Figure 2).
3. Tighten cutter feed screw handle on pipe.
4. Turn REV/OFF/FOR switch to FOR (reverse) position and step on foot switch to operate the machine (Figure 1).

Note: Cutting pipe may be done with switch in forward position but oil will continue to pump, which may be undesirable.

5. Continuously turn cutter feed screw handle with both hands until pipe is cut off.
6. Release foot switch and turn REV/OFF/FOR switch to OFF position.
7. Return pipe cutter to out-of-way position.

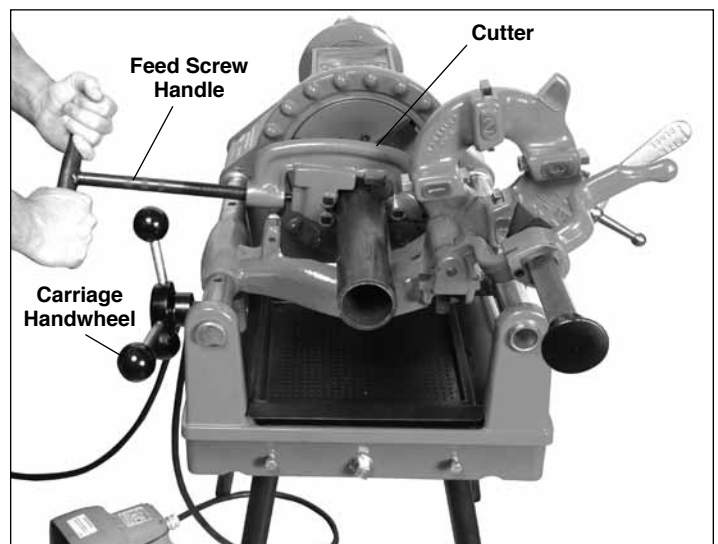

Figure 2 - Cutting pipe with cutter

Reaming Pipe with 05308 Reamer

1. Swing die head and cutter back to out-of-the-way position (Figure 3).
2. Move reamer arm down into reaming position.
3. Extend reamer by pressing latch and sliding knob toward pipe until latch engages bar.
4. Turn REV/OFF/FOR switch to FOR and press the foot switch to complete reaming by using the carriage handwheel.
5. Retract reamer bar and return reamer to out-of-way position.
6. Release foot switch and turn REV/OFF/FOR switch to OFF position.
7. Release speed chuck handwheel and centering head from pipe.
8. Remove pipe.

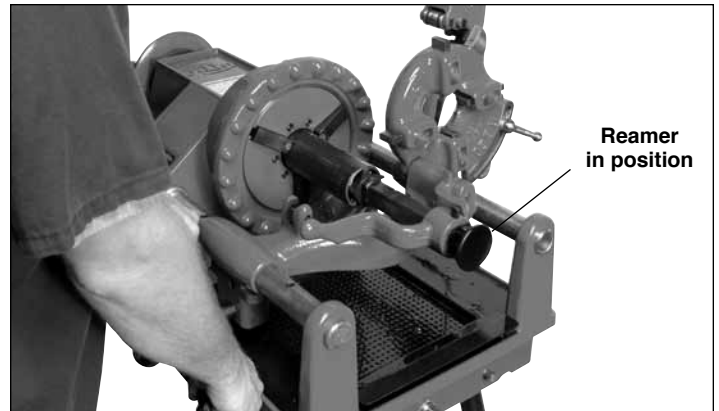

Figure 3

Threading Pipe with the R811 Die Head

1. Install die set. Refer to INSTALLING DIES (page 8) procedure.
2. Swing cutter and reamer to out-of-way position (Figure 4).
3. Lower die head into threading position.
4. Turn REV/OFF/FOR switch to FOR position and step on foot switch.
5. Engage dies with pipe using carriage handwheel, keeping slight pressure until the dies have started engagement.
6. When thread is complete, raise throwout lever to open position, retracting the dies on the R811 Universal Die Head.
7. Release foot switch and turn REV/OFF/FOR switch to OFF position.
8. Move carriage away from pipe end using carriage handwheel and return die head to up and out-of-way position.

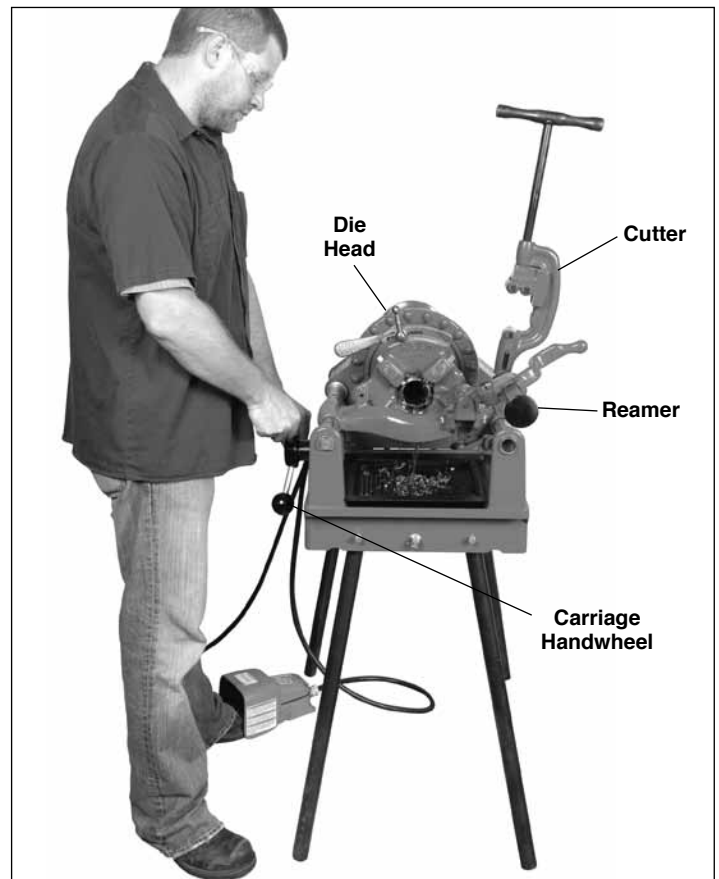

Figure 4 - Threading Pipe with Quick or self-opening die head

Installing Dies in the R811 Universal Die Head

The Universal Die Head requires one set of 4 Universal Dies to thread pipe ranging from 1/8" thru 2". One set of dies is required for each of the following pipe size ranges:

- 1/8"
- 1/4" and 3/8"
- 1/2" and 3/4"
- 1" through 2"

NOTE: BOLT THREADING REQUIRES A SEPARATE SET OF DIES FOR EACH BOLT SIZE.

1. Lay die head on bench with numbers face up.
2. Flip throwout lever to OPEN position.
3. Loosen clamp lever approximately three turns.
4. Lift tongue of clamp lever washer up out of slot under size bar. Slide throwout lever all the way to end of slot in the OVER direction indicated on size bar.
5. Remove dies from die head.
6. Die numbers 1 through 4 must agree with those on die head.
7. Insert dies to mark on side of die head.
8. Slide throwout lever back so that tongue of clamp lever washer will drop in slot under size bar.
9. Adjust die head size bar until index line on lock screw or link is aligned with proper size mark on size bar.
10. Tighten clamp lever. For bolt threads, align index line with bolt line on size bar.
11. If oversize or undersize threads are required, set the index line in direction of OVER or UNDER size mark on size bar.

MAINTENANCE INSTRUCTIONS

WARNING: ALWAYS UNPLUG POWER CORD BEFORE SERVICING THREADING MACHINE

Jaw Insert Replacement

IMPORTANT: WHEN TEETH ON JAW INSERTS BECOME WORN AND FAIL TO HOLD PIPE OR ROD DURING OPERATION, REPLACE ENTIRE SET OF JAW INSERTS. CLEAN TEETH OF JAW INSERTS DAILY WITH WIRE BRUSH.

1. Place screw driver in insert slot and turn 90 degrees in either direction (Figure 5).
2. Place insert sideways on locking pin and press down as far as possible.
3. Hold insert down firmly with screwdriver, turn teeth face up.

Lubrication

Proper lubrication is essential to trouble-free operation and long life of power drive.

Grease main shaft bearing (#95414, #95415) every 2 to 6 months depending on amount of power drive use. Grease fittings are provided on side base, one at each end of shaft. Use a good grade of cup grease.

Motor Brush Assembly

Check motor brushes (#95458) every 6 months and replace when worn to less than 1/2 inch. If commutator (#95420) is worn, turn outer dimension of commutator and undercut mica before replacing brushes.

Motor Replacement

WARNING: ALWAYS UNPLUG POWER CORD BEFORE SERVICING THREADING MACHINE.

1. Remove the Hose Assembly 45376 from the Bulkhead Union 45377 (using 2 wrenches so that the Bulkhead Union is kept from rotating).
2. Remove the Poly Tubing 95380 from the 90 deg elbow 45372.
3. Loosen the set screw on each of the Retaining Ring Assemblies 95880 and slide both support bars out of the front supports on the Oiler Base 95395.
4. Remove the Carriage from the Support Bars to reduce weight and ease handling.
5. Separate the Threading Machine from the Threading Machine base by removing nut 39032 and bolt 30097. CAUTION must be taken on this step so that no harm or damage is done.

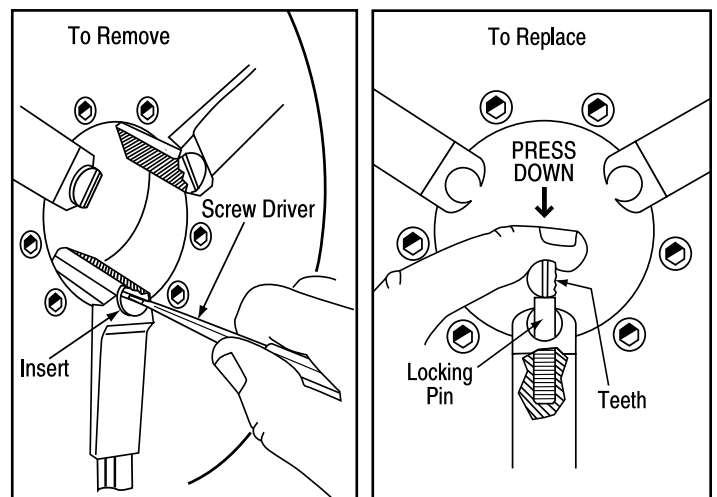

Figure 5

6. Lay the Threading Machine on its side so that the motor is accessible and the plumbing on the underneath side is not bent or damaged.
7. Unplug the motor plug 95454 from the switch box.
8. Remove 2 screws 35411 holding the motor.
9. Loosen lock screw 35403 in body at neck of the motor and lift motor out.

Self Oiling System

The pump is a self priming gerotor pump. Fill the oil reservoir with enough oil to maintain the level above the oil filter. If the filter is not covered with oil the pump will suck air causing a loss or stop in oil flow.

Tip - On occasion, the oil system may not pump or will pump with less flow than normal. This is caused by chips and other fine steel particles collecting on the outside of the oil filter in the reservoir. If this happens, turn the switch to the REV position and run the motor for about 10 seconds. Turn the switch back to the FOR position and the oil should flow freely. This is especially common if the oil reservoir has not been drained and cleaned out in a long time. If the loss or stoppage of oil flow is frequent, drain the oil and clean out the oil reservoir.

Warning: Never use a threading machine that has a leaking self-oiling system. Fix the leak prior to any further use of the machine.

INSTALLING THE LEGS ONTO THE 5401TMSO

Insert each of the 4 legs into the leg pocket on the bottom of the 5401TMSO. After inserting each leg, snug the bolt to secure the leg in place. (Figure 6)

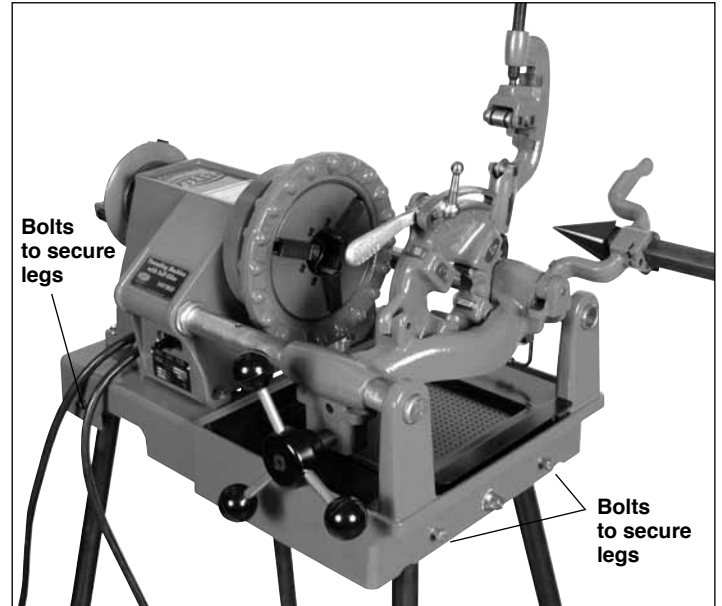

Figure 6 - 5401TMSO Threading machine with self-oiler



PIPE TOOLS & VISES
SINCE 1896

5401TMSO Threading Machine with Self-Oiler

Operator's Manual

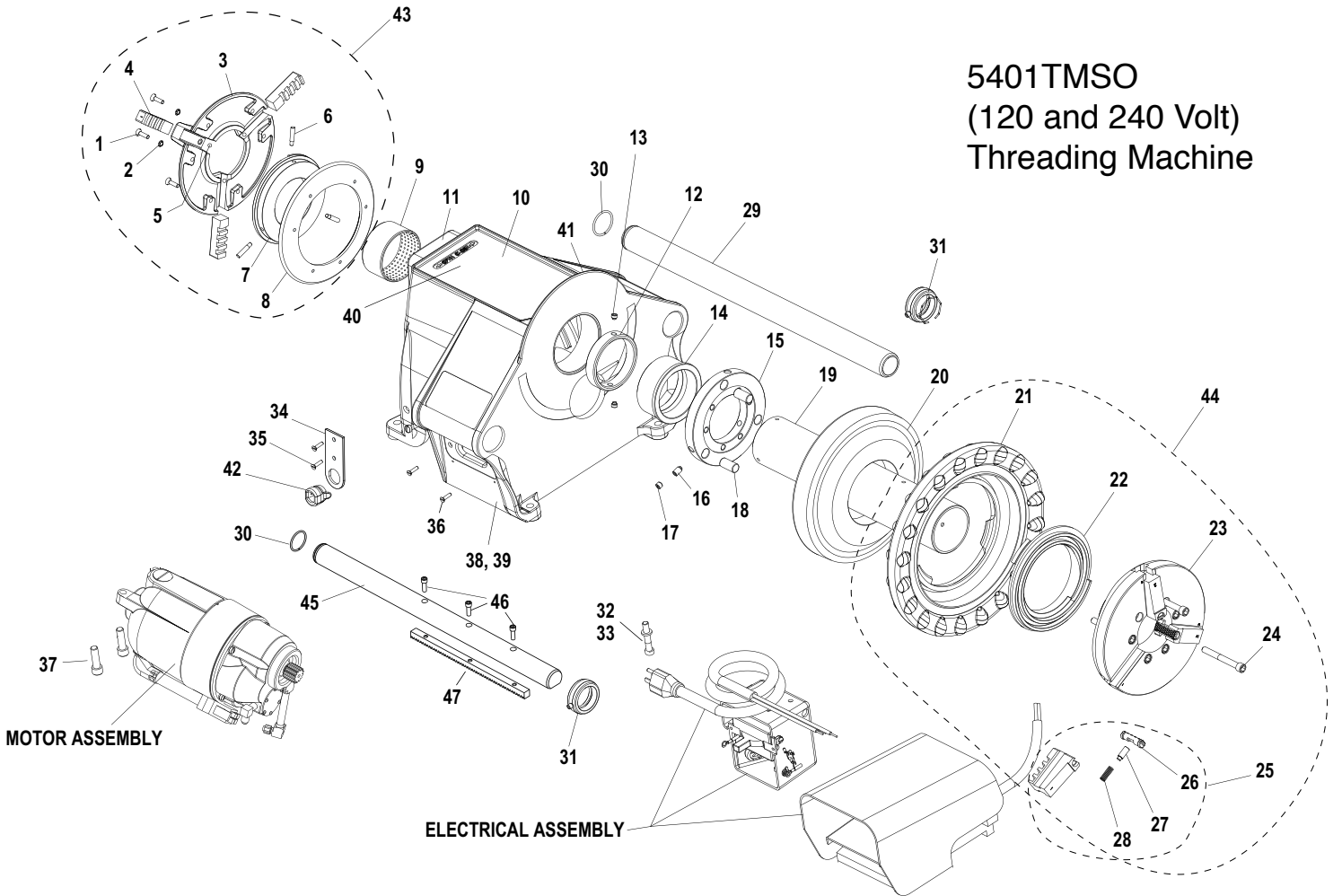

5401TMSO (120 and 240 Volt) Threading Machine

Parts List

Ref. No.	Description	Item Code	Qty.	Ridgid #
1	SCREW, SLOTTED	35400	6	46790 6/Pk
2	LOCK WASHER	35401	6	40270 6/Pk
3	CENTERING HEAD	95400	1	43735
4	REAR JAW SET	95882	1	46500
5	BALL BEARING	35406	3	—
6	STEP PIN	95411	3	45260 5/Pk
7	SCROLL, REAR	95412	1	44095
8	BACK PLATE	95401	1	43740
9	REAR BEARING	95414	1	—
10	BODY	95571	1	—
11	GREASE FITTING	40338	1	46860
12	THRUST RING	95419	1	45345
13	SET SCREW	35404	2	33785 5/Pk
14	FRONT BEARING	95415	1	—
15	DRIVE RING	95427	1	30027
16	SET SCREW	35412	3	45265 3/Pk
17	SET SCREW	35413	3	45300 5/Pk
18	DRIVE DOWEL PIN	35415	3	30022 3/Pk
19	DRIVE SHAFT	95413	1	44100
20	RING GEAR	95409	1	30017
21	HAND WHEEL	95403	1	89150

Ref. No.	Description	Item Code	Qty.	Ridgid #
22	SCROLL, FRONT	95404	1	43540
23	CAP	95405	1	43525
24	BOLT, SHCS	35405	6	45295 6/Pk
25	JAW SET, FRONT	95552	1	44090
26	JAW INSERT	95421	3	44715
27	PIN	95422	3	—
28	COMPRESSION SPRING	95451	3	—
29	SUPPORT BAR	95397	1	—
30	SPRING RING	95424	2	44525
31	RETAINING RING ASSEMBLY	95880	2	44725
32	LOCK WASHER	35429	1	—
33	BOLT, SHCS	35403	1	—
34	STRAIN RELIEF PLATE	95423	1	45825
35	SCREW	35407	2	44735 5/Pk
36	SCREW	35408	2	45280
37	BOLT, SHCS	35411	2	46745 5/Pk
38	DRIVE SCREW	37710	4	—
39a	NAME PLATE, 120V models	95418	1	—
39b	NAME PLATE, 240V models	95583	1	—
40	WARNING STICKER	95578	1	88690
41	GREASE FITTING	35450	1	—

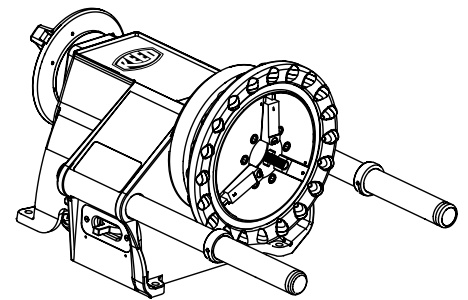

Ref. No.	Description	Item Code	Qty.	Ridgid #
42a	CORD GROMMET, 120V models	95429	1	40736
42b	CORD GROMMET, 240V models	41310	1	—
43	REAR JAW ASSEMBLY	95476	1	—
44	FRONT HANDWHEEL SCROLL / JAW ASSEM.	95484	1	—
45	SUPPORT BAR	95396	1	—
46	BOLT, SHCS	30004	3	—
47	GEAR RACK	95384	1	—

BODY BEARINGS AND HARDWARE INCLUDES:
9, 10, 11, 14, 39, 40, 41, 45, 46, 95569 1

RIDGID® is a registered trademark of RIDGID, Inc. and is not associated with Reed Manufacturing Company

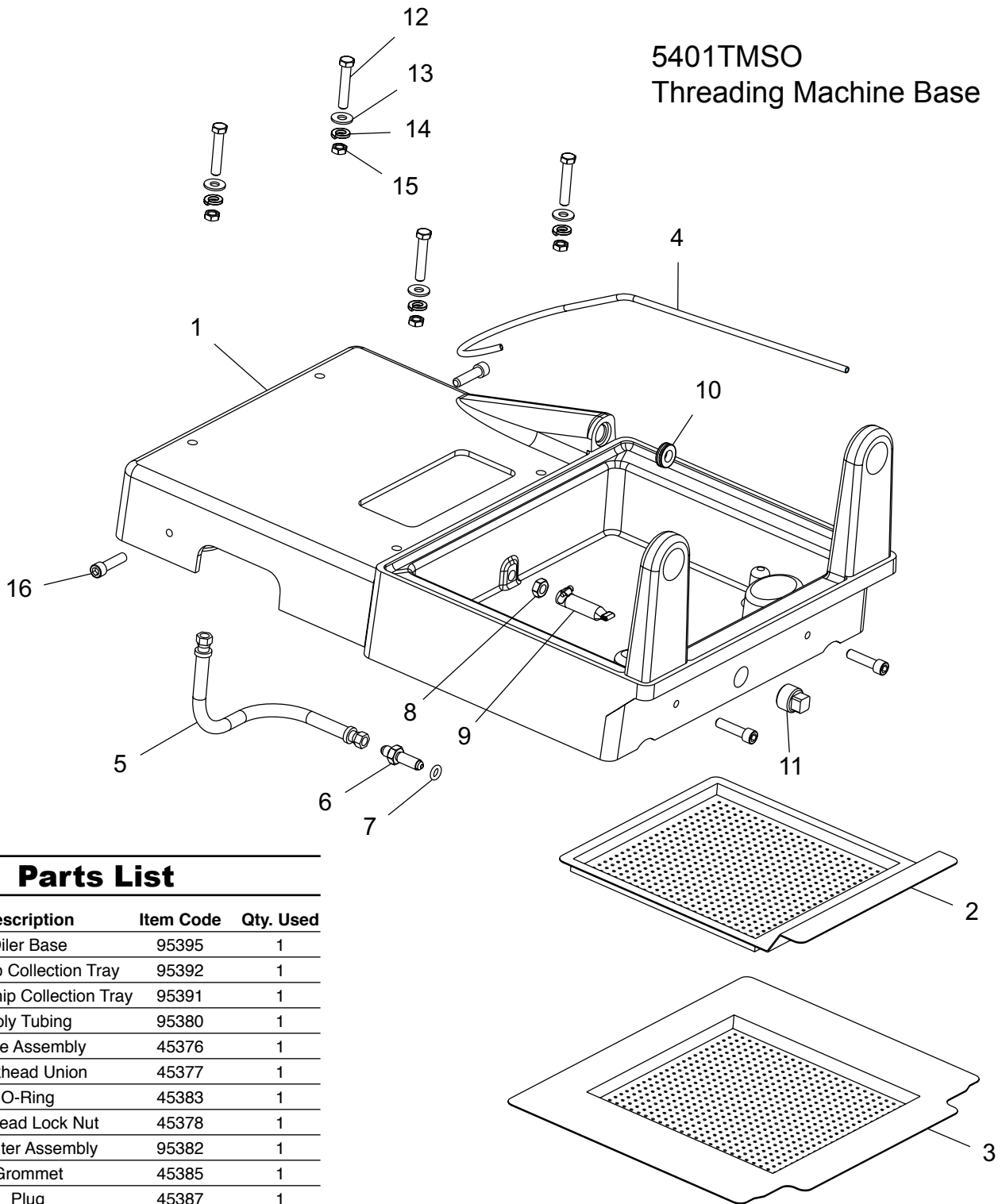

Parts List

Ref. No.	Description	Item Code	Qty. Used
1	Oiler Base	95395	1
2	Top Chip Collection Tray	95392	1
3	Bottom Chip Collection Tray	95391	1
4	Poly Tubing	95380	1
5	Hose Assembly	45376	1
6	Bulkhead Union	45377	1
7	O-Ring	45383	1
8	Bulkhead Lock Nut	45378	1
9	Oil Filter Assembly	95382	1
10	Grommet	45385	1
11	Plug	45387	1
12	3/8-16 Bolt	30097	4
13	3/8" Washer	30011	4
14	3/8" Lock Washer	30033	4
15	3/8-16 Nut	39032	4
16	3/8-16X1-1/2 SHCS	30217	4



PIPE TOOLS & VISES
SINCE 1896

5401TMSO (120 Volt)
Motor Assembly

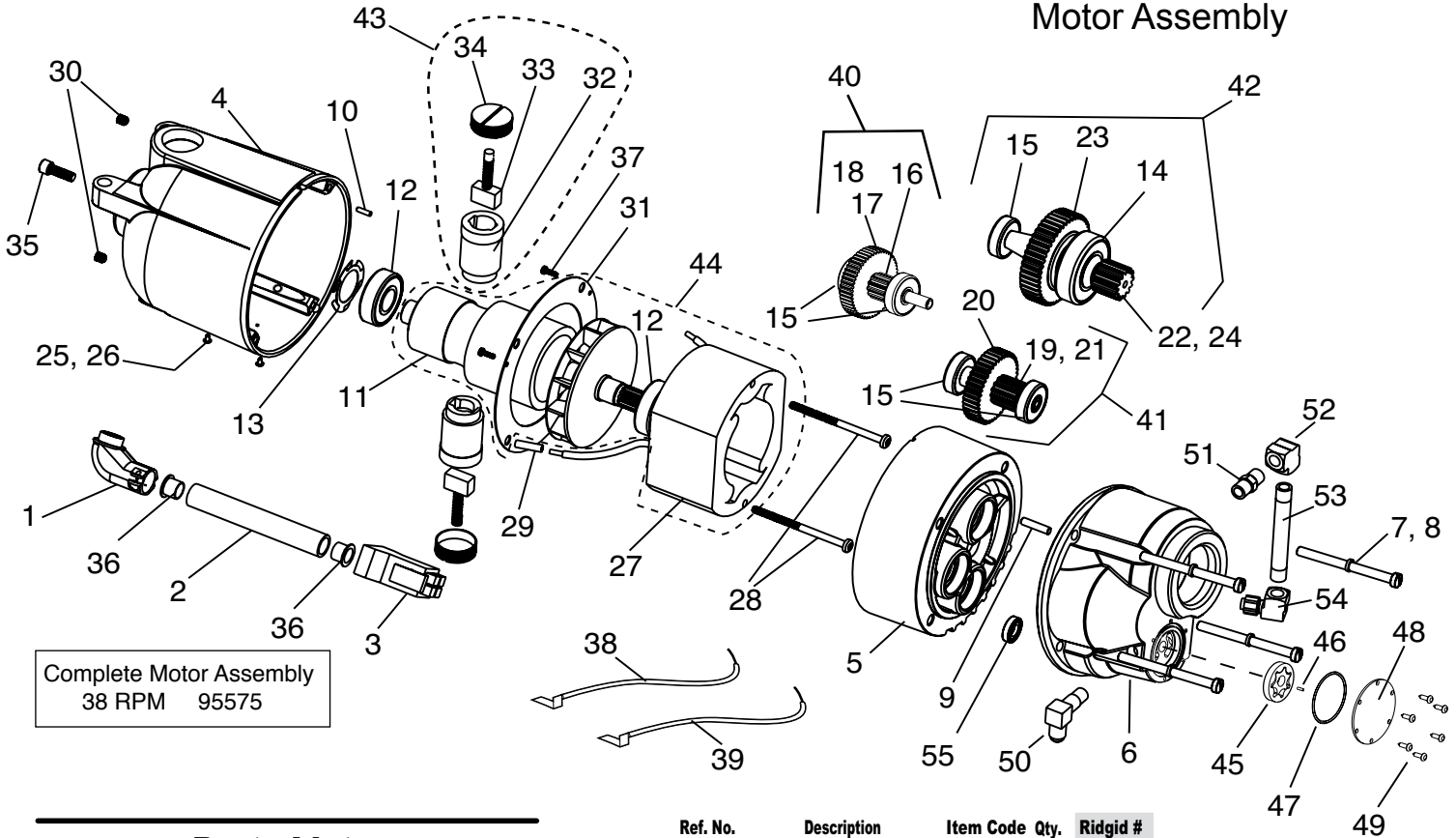

Parts List

Ref. No.	Description	Item Code	Qty.	Ridgid #
1	90° CONNECTOR	95452	1	46900
2	CONDUIT	95453	1	—
3	PLUG	95454	1	46830
4	MOTOR HOUSING	95406	1	—
5	FAN HOUSING	95407	1	43165
6	GEAR COVER WITH PUMP CAVITY	95540	1	96830
7	LOCK WASHER	35428	4	45150 5/Pk
8	SCREW	35427	4	45075 5/Pk
9	DOWEL PIN	95417	1	—
10	DOWEL PIN	35430	1	—
11	ARAMATURE W/FAN	95572	1	44010
12	BEARING	98855	2	44565
13	FINGER DISK SPRING	95445	1	44580
14	BEARING	98845	1	45315
15	BEARING	98846	5	45060
16	GEAR SHAFT - 1ST	95595	1	—
17	SPUR GEAR	98809	1	44985
18	KEY	48807	1	44985
19	GEAR SHAFT - 2ND- 38 RPM - 57 RPM	95448 95564	1 1	45005 45005
20	SPUR GEAR	95447	1	45005
21	KEY	48810	1	45005
22	GEAR SHAFT - 3RD	95450	1	45370
23	SPUR GEAR - 38 RPM - 57 RPM	95449 95563	1 1	45370 45370
24	KEY	48816	1	45370
25	NAME PLATE	95456	1	—
26	DRIVE SCREW	30133	2	85920 5/Pk

Ref. No.	Description	Item Code	Qty.	Ridgid #
27	FIELD	95573	1	86690 2/Pk
28	FIELD SCREW	98848	2	44555 2/Pk
29	INSULATOR TUBE	98885	2	—
30	SET SCREW	30018	2	39770 5/Pk
31	FAN PLATE	95474	1	—
32	BRUSH HOLDER	95455	2	—
33	BRUSH ASSEMBLY, PAIR	95570	1	44540
34	BRUSH CAP	95459	2	—
35	LOCK SCREW	35435	1	—
36	BUSHING PLASTIC	35434	2	—
37	SCREW	35449	3	—
38	BRUSH LEAD, BLUE w/TERMINAL	95580	1	—
39	BRUSH LEAD, WHITE w/TERMINAL	95579	1	—
40	SHAFT ASSEMBLY 1	95399	1	—
41	SHAFT ASSEMBLY 2 - 38 RPM	95479	1	45005
42	SHAFT ASSEMBLY 3 - 38 RPM 57 RPM	95480 95550	1 1	45370
43	BRUSH/HOLDER/CAP ASSEMBLY	95585	2	—
44	FIELD & ARMATURE	95587	1	—
45	GEROTOR SET	95592	1	96870
46	DOWEL PIN	35596	1	96885
47	O-RING	35595	1	96875
48	PUMP COVER	95591	1	96840
49	SCREWS	35594	6	96890
50	90° LONG ELBOW (JIC/PIPE)	45379	1	—
51	HEX NIPPLE	45375	1	—
52	90° ELBOW	45374	1	—
53	PIPE NIPPLE	45373	1	—
54	90° ELBOW (POLY/PIPE)	45372	1	—
55	OIL SEAL	45596	1	—

See Ref. No. 43

See Ref. No. 40

See Ref. No. 41

See Ref. No. 42



PIPE TOOLS & VISES
SINCE 1896

5401TMSO (240 Volt)
Motor Assembly

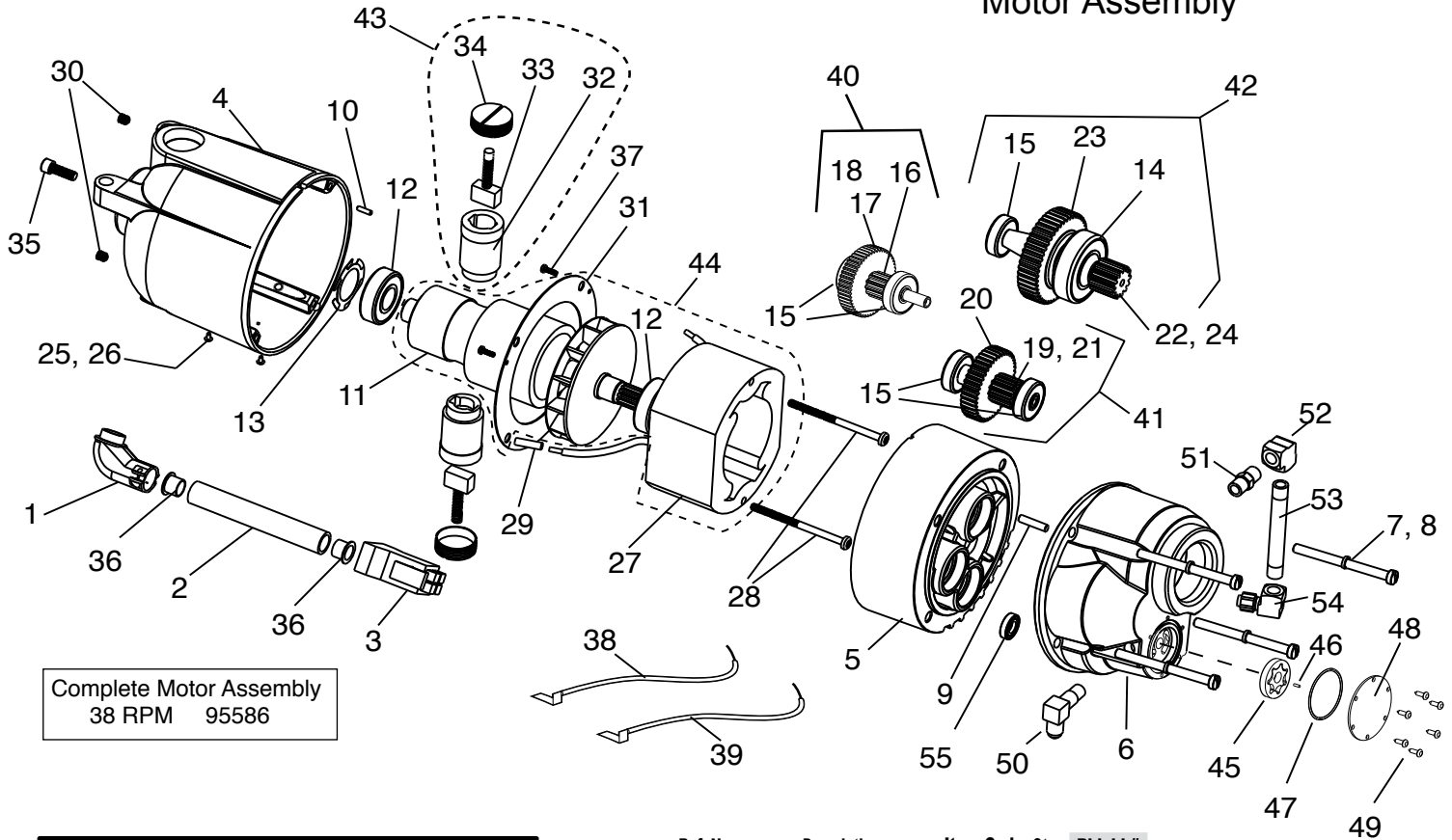

Complete Motor Assembly
38 RPM 95586

Parts List

Ref. No.	Description	Item Code	Qty.	Ridgid #
1	90° CONNECTOR	95452	1	46900
2	CONDUIT	95453	1	—
3	PLUG	95454	1	46830
4	MOTOR HOUSING	95406	1	—
5	FAN HOUSING	95407	1	43165
6	GEAR COVER WITH PUMP CAVITY	95540	1	96830
7	LOCK WASHER	35428	4	45150 5/Pk
8	SCREW	35427	4	45075 5/PK
9	DOWEL PIN	95417	1	—
10	DOWEL PIN	35430	1	—
11	ARAMATURE W/FAN AND BEARINGS	95436	1	—
12	BEARING	98855	2	44565
13	FINGER DISK SPRING	95445	1	44580
14	BEARING	98845	1	45315
15	BEARING	98846	5	45060
16	GEAR SHAFT - 1ST	95595	1	—
17	SPUR GEAR	98809	1	44985
18	KEY	48807	1	44985
19	GEAR SHAFT - 2ND- 38 RPM	95448	1	45005
20	SPUR GEAR	95447	1	45005
21	KEY	48810	1	45005
22	GEAR SHAFT - 3RD	95450	1	45370
23	SPUR GEAR - 38 RPM	95449	1	45370
24	KEY	48816	1	45370
25	NAME PLATE	95582	1	—
26	DRIVE SCREW	30133	2	85920 5/PK

See Ref. No. 40

See Ref. No. 41

See Ref. No. 42

Ref. No.	Description	Item Code	Qty.	Ridgid #
27	FIELD, 240V	95544	1	—
28	FIELD SCREW	98848	2	44555 2/PK
29	INSULATOR TUBE	98885	2	—
30	SET SCREW	30018	2	39770 5/Pk
31	FAN PLATE	95474	1	—
32	BRUSH HOLDER	95455	2	—
33	BRUSH ASSEMBLY, PAIR	95542	1	—
34	BRUSH CAP	95459	2	—
35	LOCK SCREW	35435	1	—
36	BUSHING PLASTIC	35434	2	—
37	SCREW	35449	3	—
38	BRUSH LEAD, BLUE w/TERMINAL	95580	1	—
39	BRUSH LEAD, WHITE w/TERMINAL	95579	1	—
40	SHAFT ASSEMBLY 1	95399	1	—
41	SHAFT ASSEMBLY 2 - 38 RPM	95479	1	45005
42	SHAFT ASSEMBLY 3 - 38 RPM	95480	1	45370
43	BRUSH/HOLDER/CAP ASSEMBLIES	95543	1	—
44	FIELD/ARMATURE SET W/BEARINGS	95546	1	—
45	GEROTOR SET	95599	1	96870
46	DOWEL PIN	35596	1	96885
47	O-RING	35595	1	96875
48	PUMP COVER	95591	1	96840
49	SCREWS	35594	6	96890
50	90° LONG ELBOW (JIC/PIPE)	45379	1	—
51	HEX NIPPLE	45375	1	—
52	90° ELBOW	45374	1	—
53	PIPE NIPPLE	45373	1	—
54	90° ELBOW (POLY/PIPE)	45372	1	—
55	OIL SEAL	45596	1	—

See Ref. No. 43

RIDGID® is a registered trademark of RIDGID, Inc. and is not associated with Reed Manufacturing Company

CARRIAGE #05367
5401TMSO Carriage
with Handwheel

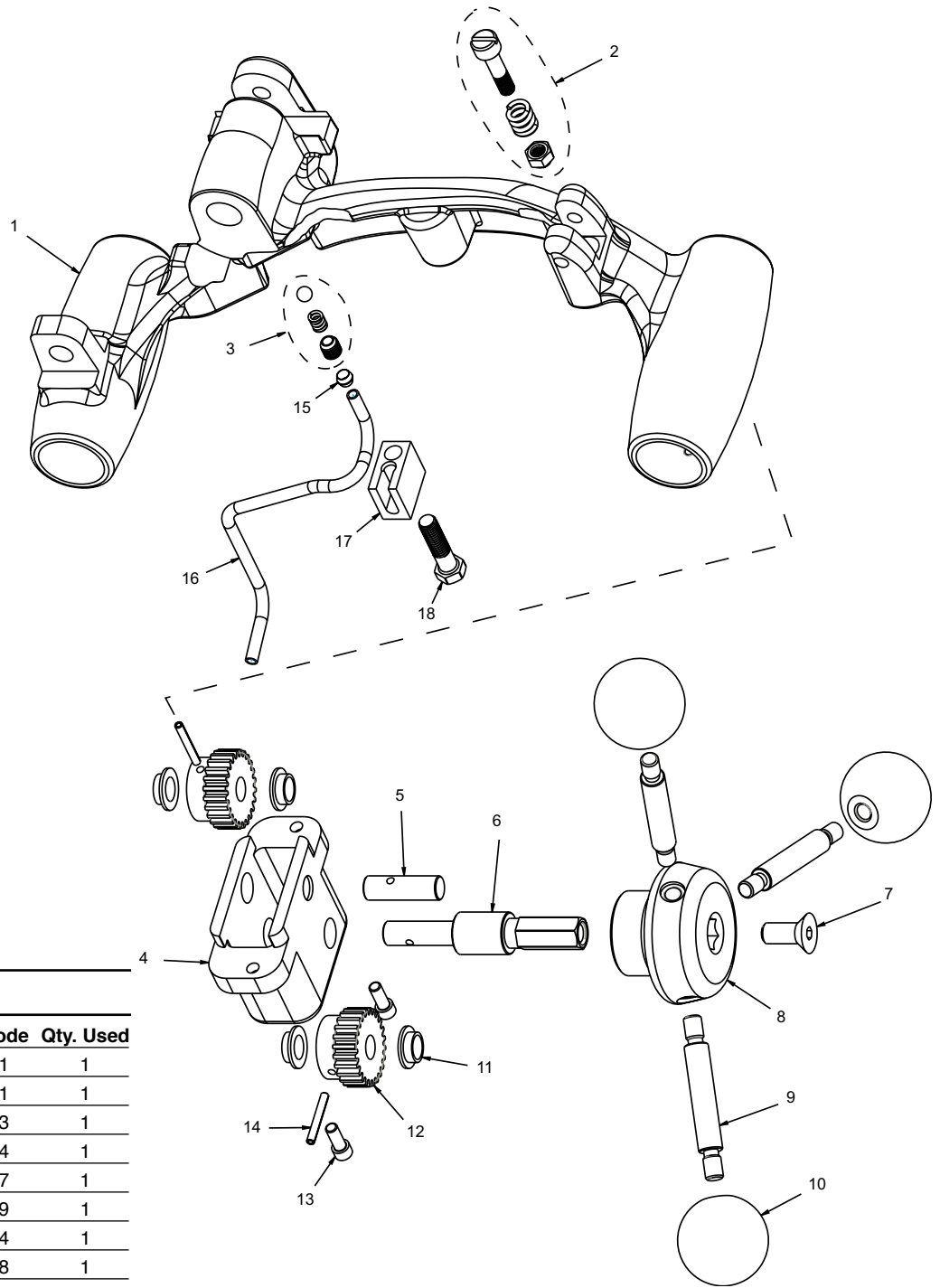

Parts List

Ref. No.	Description	Item Code	Qty. Used
1	Carriage Body	95381	1
2	Stop Bolt Assembly	95881	1
3	Ball Retainer Kit	95883	1
4	Handwheel Bracket	95394	1
5	Idler Shaft	95387	1
6	Handwheel Shaft	95389	1
7	Flat Socket Head Cap Screw	35294	1
8	Handwheel Hub	95388	1
9	Handwheel Spoke	95390	3
10	Ball Knob	40054	3
11	Bronze Bushing	40461	4
12	Gear	95386	2
13	1/4-20 X 5/8 SHCS	30105	2
14	Spirol Pin	30233	2
15	1/4" Ferrule	45719	1
16	Bent Tube	45370	1
17	Tube Retainer Block	95590	1
18	3/8-16 X 1-1/2L Bolt	35590	1



PIPE TOOLS & VISES
SINCE 1896

5401TMSOCUTTER #05366
5401TMSO Pipe Cutter

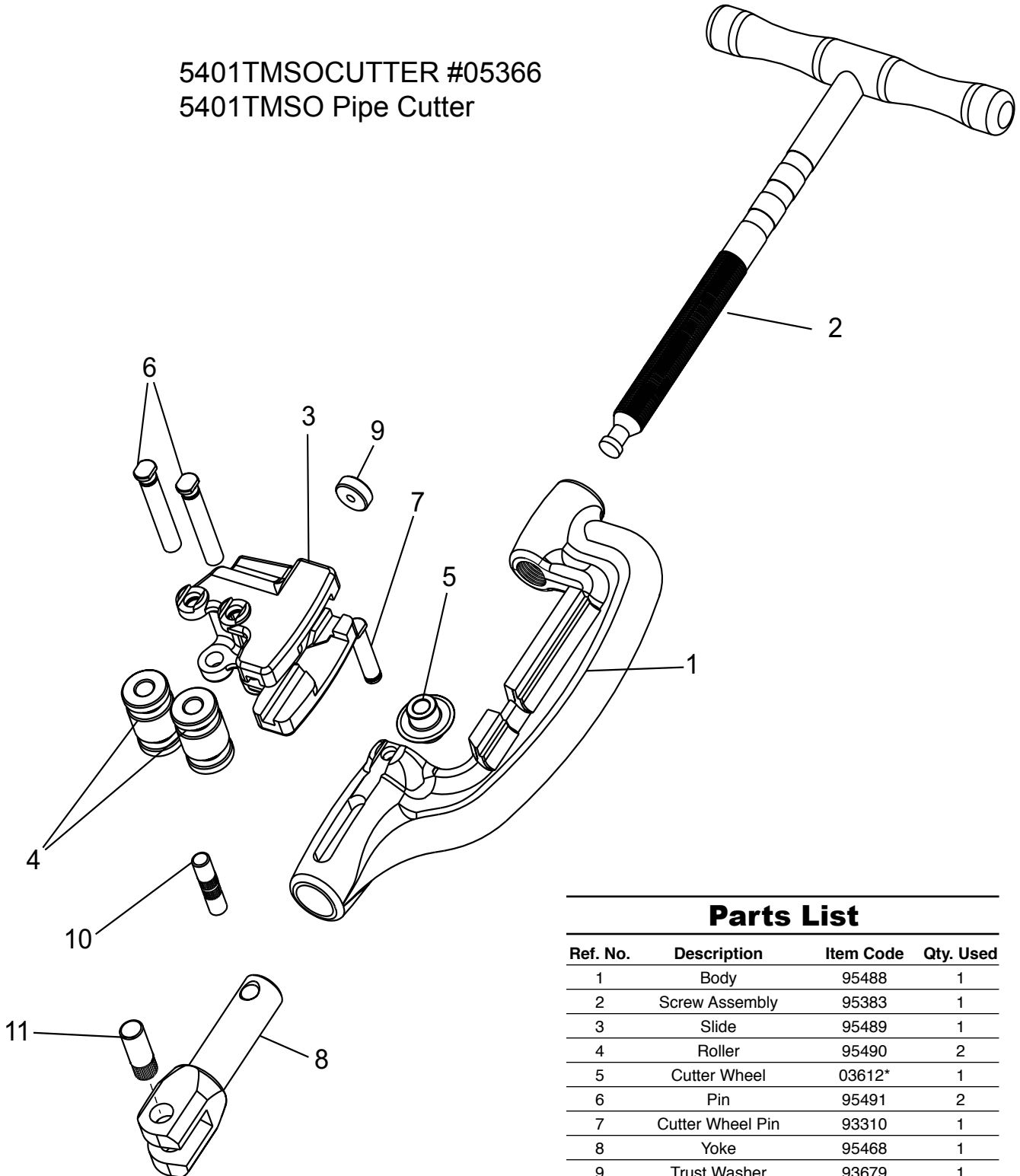

Parts List

Ref. No.	Description	Item Code	Qty. Used
1	Body	95488	1
2	Screw Assembly	95383	1
3	Slide	95489	1
4	Roller	95490	2
5	Cutter Wheel	03612*	1
6	Pin	95491	2
7	Cutter Wheel Pin	93310	1
8	Yoke	95468	1
9	Trust Washer	93679	1
10	Knurled Pin	95560	1
11	1/2 x 1-1/4 Pin	95561	1

*Use optional Cutter Wheel #03613 to have a heavy duty wheel for cutting steel and stainless steel.

Reamer #05308

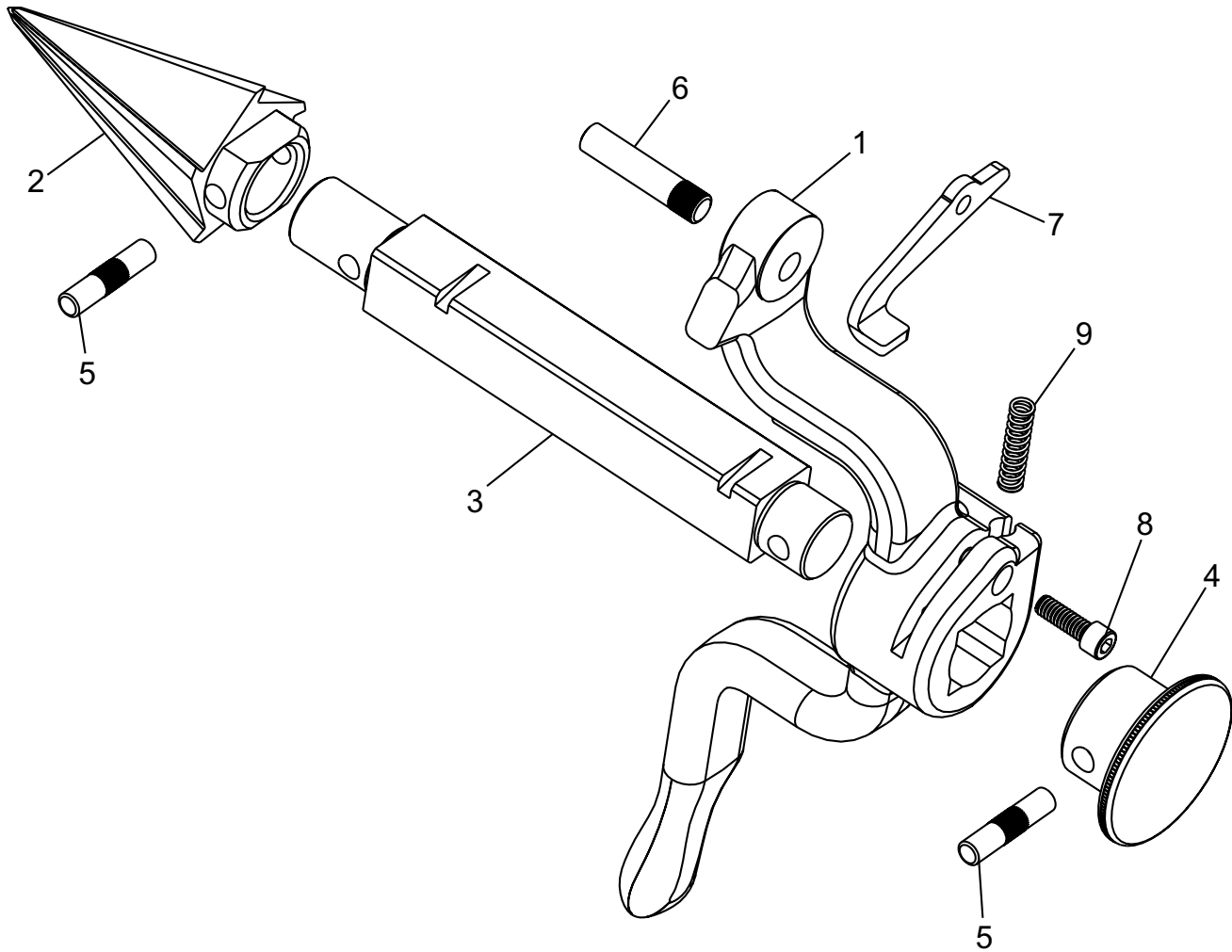

Parts List

Ref. No.	Description	Item Code	Qty. Used
1	Arm	95487	1
2	Reamer	95492	1
3	Bar	95493	1
4	Knob	95494	1
5	Pin	95495	2
6	Hinge Pin	95496	1
7	Latch	95497	1
8	1/4 x 3/4" Pin	30004	1
9	Spring	95451	1

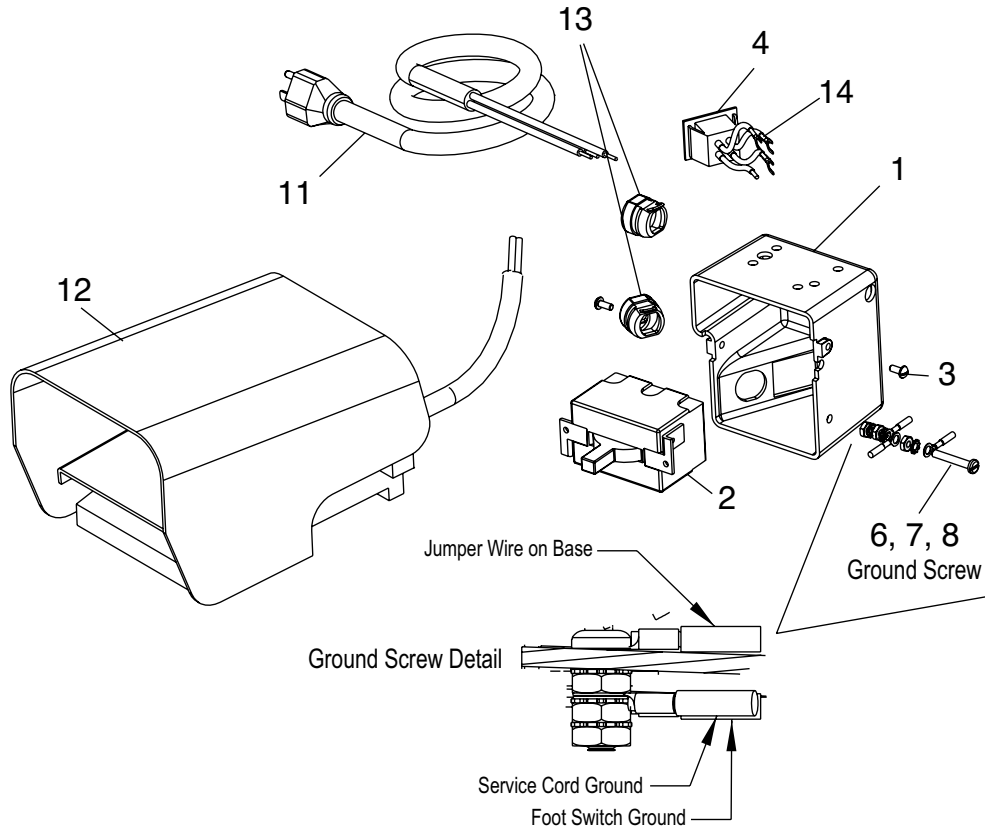

5401TMSO (120 Volt) Electrical Assembly

Parts List

Ref. No.	Description	Item Code	Qty.	Ridgid #
1	SWITCH BOX	95430	1	—
2	SWITCH	95557	1	44505
3	SCREW	30106	2	—
4	OUTLET JUMPER ASSY.	95556	1	—
5	RING TONGUE TERMINAL	98859	3	—
6	SCREW (GROUND)	30159	1	—
7	LOCK WASHER	35423	3	46985 5/Pk
8	HEX NUT	30117	3	—
9	GROUND WIRE	95438	1	—
10	SCREW	35431	1	—
11	LINE CORD W/PLUG	95432	1	46740
12	FOOT SWITCH W/CORD	95574	1	36642
13	CORD GROMMET	95429	3	46735
14	SPADE TERMINAL	35436	4	—

RIDGID® is a registered trademark of RIDGID, Inc. and is not associated with Reed Manufacturing Company

5401TMSO (120 Volt)
Wiring Schematic

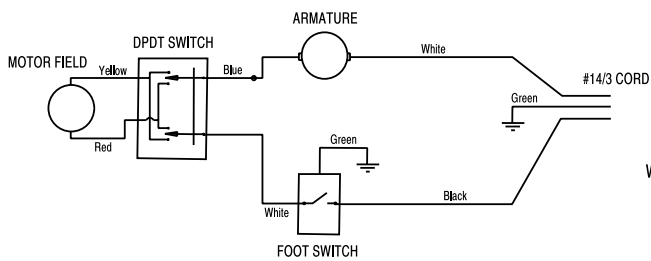

5401TMSO (120 Volt)
Wiring Diagram

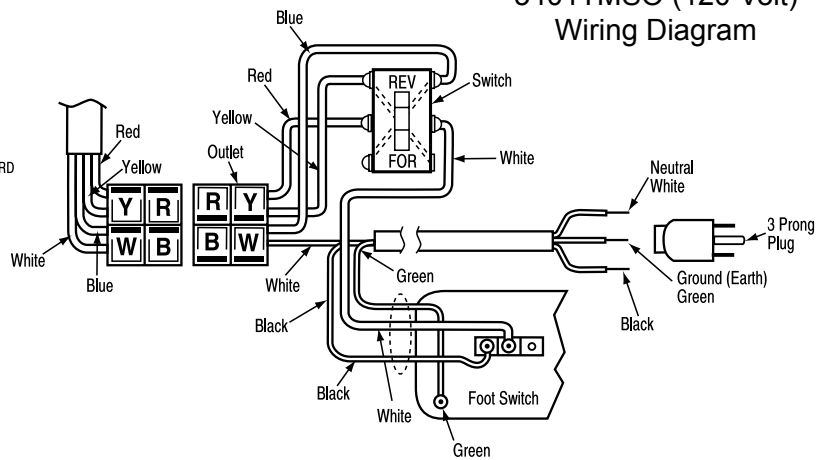

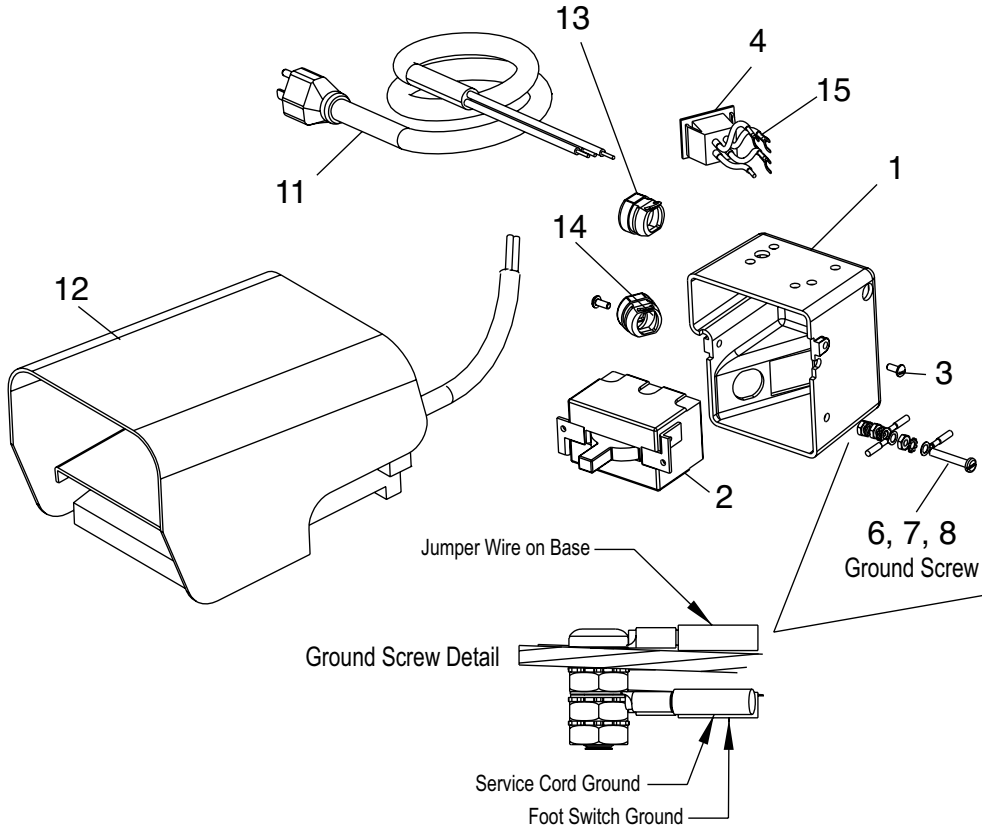

5401TMSO (240 Volt) Electrical Assembly

Parts List

Ref. No.	Description	Item Code	Qty.	Ridgid #
1	SWITCH BOX	95430	1	—
2	SWITCH	95557	1	44505
3	SCREW	30106	2	—
4	OUTLET JUMPER ASSY.	95556	1	—
5	RING TONGUE TERMINAL	98859	3	—
6	SCREW (GROUND)	30159	1	—
7	LOCK WASHER	35423	3	46985 5/Pk
8	HEX NUT	30117	3	—
9	GROUND WIRE	95438	1	—
10	SCREW	35431	1	—
11	LINE CORD W/PLUG	95461	1	—
12	FOOT SWITCH W/CORD	95574	1	36642
13	CORD GROMMET	95429	1	46735
14	CORD GROMMET	41310	1	—
15	SPADE TERMINAL	35436	4	—

RIDGID® is a registered trademark of RIDGID, Inc. and is not associated with Reed Manufacturing Company

5401TMSO (240 Volt) Wiring Schematic

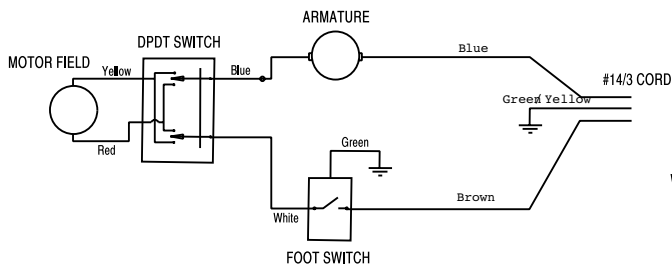

5401TMSO (240 Volt) Wiring Diagram

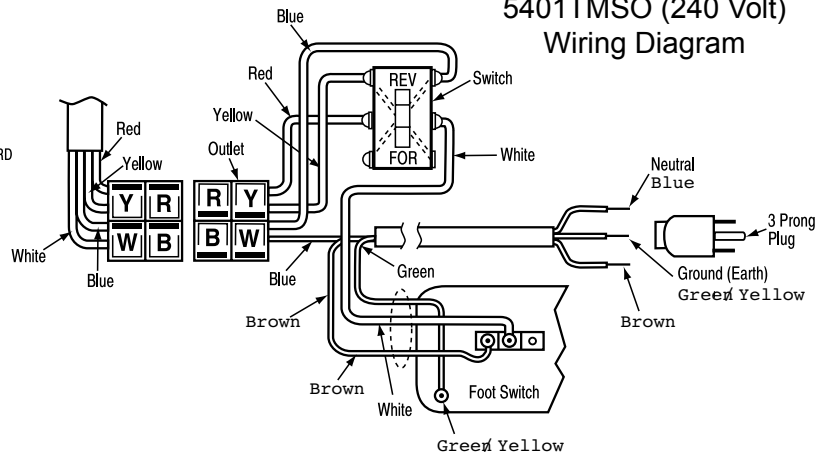

REED Warranty

REED will repair or replace tools with any defects due to faulty materials or workmanship for one (1) year or five (5) years from the date of purchase, as applicable. This warranty does not cover part failure due to tool abuse, misuse, or damage caused where repairs or modifications have been made or attempted by non REED authorized repair technicians. This warranty applies only to REED tools and does not apply to accessories. This warranty applies exclusively to the original purchaser.

One (1) year warranty: Power units for pneumatic, electric, hydraulic and battery-powered tools have a one year warranty. This includes, but is not limited to REED pumps, universal pipe cutter motors, power drives, power bevel tools, threading machines, cordless batteries and chargers.

Five (5) year warranty: Any REED tool not specified under the one (1) year warranty above is warranted under the REED five (5) year warranty.

NO PARTY IS AUTHORIZED TO EXTEND ANY OTHER WARRANTY. NO WARRANTY FOR MERCHANTABILITY OR FITNESS FOR A PARTICULAR PURPOSE SHALL APPLY.

No warranty claims will be allowed unless the product in question is received freight prepaid at the REED factory. All warranty claims are limited to repair or replacement, at the option of REED, at no charge to the customer. REED is not liable for any damage of any sort, including incidental and consequential damages. This warranty gives you specific legal rights, and you may also have other rights which vary by state, province or country.

